

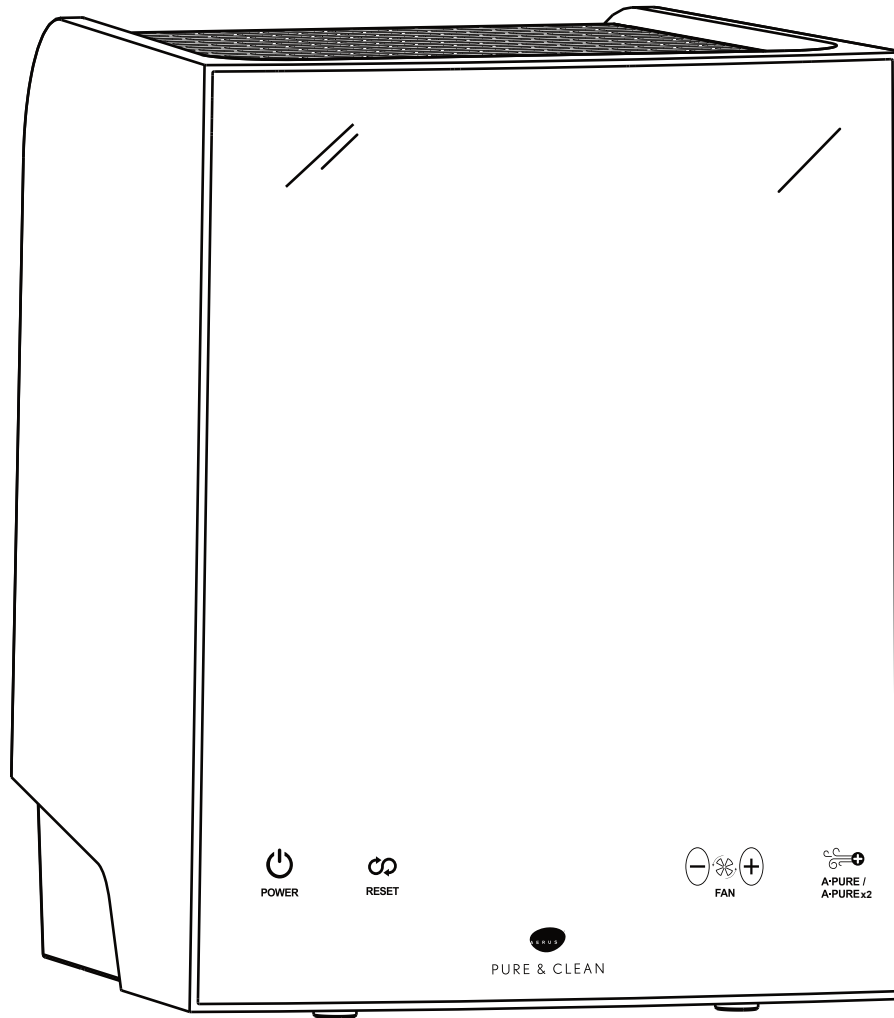

PURE & CLEAN



PORTABLE AIR PURIFICATION SYSTEM

READ MANUAL CAREFULLY FOR PROPER USE AND OPERATION.



2017 Space Technology
Hall of Fame Inductee

Nature's Healthy Ions

GENERAL INFORMATION

PRODUCT OVERVIEW

Congratulations, you have purchased one of the most effective, technologically advanced air purifiers available. Your new Aerus Pure & Clean is designed to provide years of trouble-free, low maintenance operation. Be sure to read and follow all service procedures outlined in this owner's manual, and use only genuine Aerus replacement parts available from your Aerus Distributor.

CONTENTS

Introduction.....	2
Specifications	2
Important Safety Instructions.....	3
Your New Aerus Pure & Clean	4
Inspection & Installation	4
Unit Features.....	4
Operation	5
Placement of Unit	5
Settings & Adjustments.....	6
LCD Display	6
Maintenance Reminders.....	7
General Maintenance.....	7
Optional HEPA Filter Sheet.....	8
Removing the Filter Assembly	9
Removing the ActivePure® Cell.....	10
Installing the ActivePure® Cell.....	10
Troubleshooting.....	11
Replacement Parts	12
Warranty Information.....	13

SPECIFICATIONS

Electrical:

- 100 ~ 240 VAC 50/60 Hz External Power Supply
- 43 watts maximum power consumption
- Positive and Negative ion generation

Size:

- Dimensions:
11.75" high x 9.5" wide x 10" deep
- Weight: 7.6 pounds

Coverage:

- Covers a range of 500 sq. ft. (42 m²) to 3,000 sq. ft. (279 m²)**

** Depends on variables such as severity and frequency of pollution, humidity, and temperature.

Warranty:

- Three (3) year limited warranty

FILL IN AND SAVE

Please record the name and phone number of your Aerus Distributor here, and retain it for future reference.

Name _____

Phone _____

Serial # _____

If you have any questions concerning this, or any Aerus product, contact your Aerus Distributor or Aerus Customer Service at 800.243.9078 (U.S.) or 800.668.0763 (CANADA).

IMPORTANT SAFETY INSTRUCTIONS

**WARNING:**

- When using electrical appliances, basic precautions should always be followed to reduce risk of fire, electric shock, and injury to persons, including the following:
- Eye damage may result from directly viewing the light produced by the lamp used in this product; always turn off & unplug unit before removing filters or bulbs
- Do not operate this unit without the Filter Assembly AND Back Cover installed
- Disconnect power cord before servicing

**CAUTION:**

- Allow your Aerus Pure & Clean to warm to room temperature before operating; damage may result from turning on a cold unit

**CAUTION:**

- Do not operate unit near heat sources, open flame, or combustible vapors or gases.

Read this manual in its entirety before using your Aerus Pure & Clean

- NEVER locate air cleaner where it may fall into a bathtub or other water container; to protect against electrical hazards, DO NOT immerse in water or other liquids
- DO NOT touch the control panel or plug with a wet hand
- DO NOT run cord under carpeting; DO NOT cover cord with throw rugs, runners, or similar coverings; arrange cord away from traffic area and where it will not be tripped over
- DO NOT insert or allow foreign objects to enter any ventilation or exhaust opening as this may cause an electric shock or fire, or damage the air cleaner
- To prevent a possible fire, DO NOT block the air intakes or exhaust in any manner; DO NOT use on soft surfaces, like a bed, where openings may become blocked
- To avoid fire or shock hazard, plug the unit directly into an electrical outlet
- To disconnect air cleaner, turn controls to OFF, then remove plug from outlet; pull firmly on the plug, DO NOT unplug by pulling on the cord
- Always unplug the unit before moving or cleaning, or whenever the air cleaner is not in use
- DO NOT use outdoors or on wet surfaces
- DO NOT attempt to repair or adjust any electrical or mechanical functions on this unit, doing so will void your warranty
- Connect to properly grounded outlets only
- To reduce the risk of electrical shock, do not change the plug in any way; do not use adaptors

SAVE THESE INSTRUCTIONS

YOUR NEW AERUS PURE & CLEAN

- Removes airborne and surface contaminants like mold, bacteria, fungi and viruses
- Includes our exclusive patented ActivePure® Technology (#9.867.897)
- Reduces odors, smoke and tobacco smells
- Improves the quality of indoor air and surfaces, up to 3,000 sq. ft. (279 m²)
- Safe for human, pets and plants when used as directed
- New patent pending cell design
- Customizable to your environment, using the controls on the front of the unit
- Maintenance Reminders alert you when normal maintenance needs to be performed or service is required

INSPECTION & INSTALLATION

1. Remove protective packaging
2. Remove unit from shipping carton
3. Remove all protective materials
4. Check for shipping damage and loose or broken parts
5. Read Owner's Manual thoroughly prior to installation
6. Determine placement location for the unit (See "Placement of Unit" on page 5)
7. Insert the Power Supply Plug into the power receptacle on the rear of the unit. Plug the appropriate cord into the Power Supply and into a working electrical outlet
8. Using the Power button, turn the unit ON

UNIT FEATURES

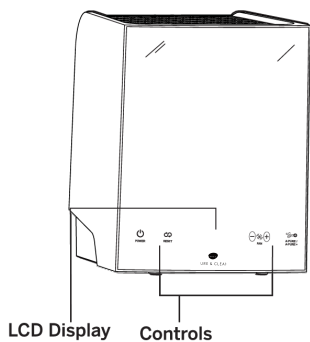

- Exclusive ActivePure® Technology
- Positive and Negative Multipoint and RF Ion Generation
- Five Speed Fan
- LCD Display
- Maintenance Reminders
- Replaceable ActivePure® Cells
- Removable Rear Grill
- Universal Power Supply with cords

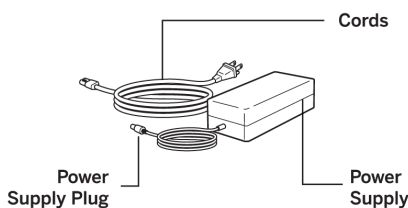
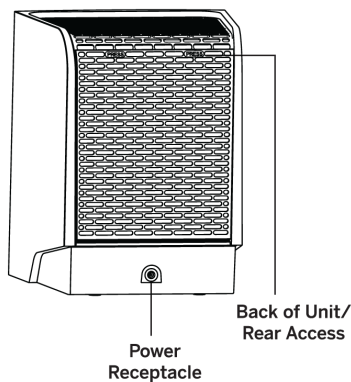

OPERATION

1. Adjust the fan speed to your preference, keeping in mind that higher fan speeds will give better results.
2. Using the A-PURE/A-PURE x2 button, set the unit to A-PURE, for typical use, or A-PURE x2, for increased smoke and odor control.

A-PURE MODE: The unit's display shows the fan speed (low to high) and A-PURE to indicate that the ActivePure® Cell and ionization are both functioning normally.

A-PURE x2 MODE: A-PURE x2 lights up, indicates that (2) ActivePure® Cells and ionization are both functioning normally.

ION MODE: Ion lights up, indicates only ionization is functioning.

POWER OUTAGES: Memory before power off settings.

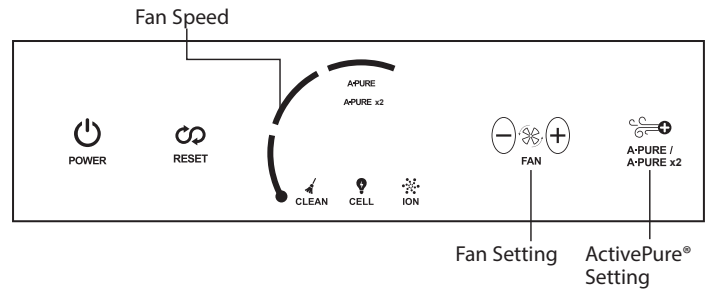

PLACEMENT OF UNIT



CAUTION: To prevent injury, be sure the power cord is not accessible to small children.

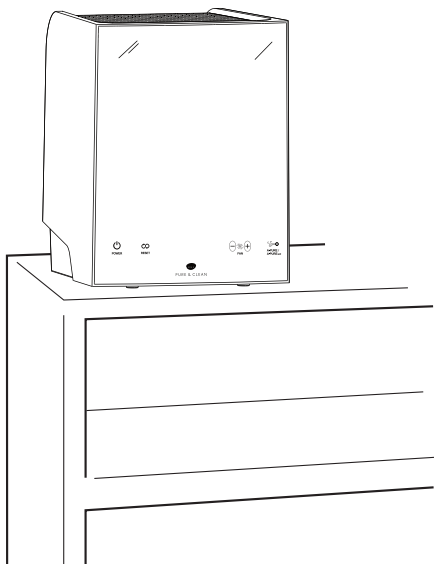

Suggested locations listed in the order of preference:

1. Nearest the source of the worst pollution.
2. Near a cold-air return to thoroughly circulate the benefits of your Aerus Pure & Clean throughout the area.
3. In the area most heavily used to achieve maximum benefit.

NOTE: The rear of the unit should always have at least one inch of open area to allow unrestricted airflow.

SETTINGS & ADJUSTMENTS

The Aerus Pure & Clean can be turned on or off, and adjusted, using the control panel on the front of the unit.

NOTE: If you are operating your central heating and air conditioning fan or other ventilation system continuously, set the coverage up to the total ventilated indoor area. Otherwise, set the coverage up to the size of the room.

POWER (stand by)
Turns the unit ON and OFF.

FAN UP/FAN DOWN
Adjusts the five speed fan.

A-PURE/A-PURE x2
Toggles the unit between A-PURE Mode (ActivePure® and Ionization) and A-PURE x2 Mode (ActivePure® Cells and Ionization).

REMINDER RESET
Clears the maintenance reminders after performing routine maintenance.

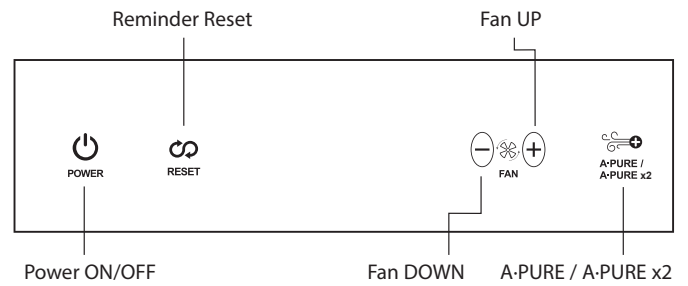

LCD DISPLAY

The LCD Screen is used to display all current settings (see page 5) as well as any maintenance reminders.

If a maintenance reminder or a service reminder appears, the backlight will brighten and constantly flash until the Reminder Reset button is pressed or the service problem is corrected.

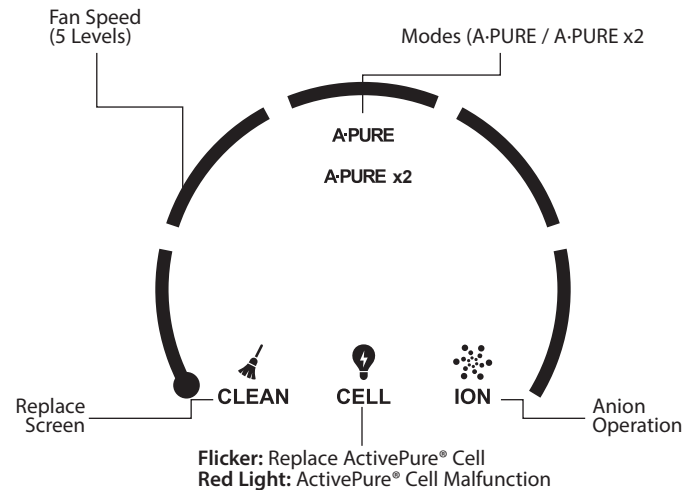

MAINTENANCE REMINDERS

When maintenance is required, the Display Screen will brighten and flash and the maintenance reminder will appear.

REPLACE RCI CELL CELL

The ActivePure® Cell is no longer working correctly.

- Replace the ActivePure® Cell (replacement cells are available from your local Aerus Distributor)

NOTE: The ActivePure® Cell should be replaced every two (2) years, even if the unit does not display this message.

PERFORM CLEANING CLEAN

(approx. every 30 days)

- Clean the Filter Assembly (see page 8)
- Vacuum the ActivePure® Cells
- Vacuum Top and Rear Grill Openings

NOTE: Be sure to press the Reminder Reset button to clear the reminder following regular maintenance (see below).

RESETTING THE REMINDERS

The reminder you need to reset is the PERFORM CLEANING and PERFORM RCI CELL reminder (after performing maintenance, press the Reset button and the screen will stop flashing to let you know the reminder has been cleared). All the other service reminders will clear automatically once the unit has been turned off and back on and the problem has been corrected.

GENERAL MAINTENANCE



CAUTION: Unplug the unit before performing any maintenance procedures.

Periodic maintenance is required to ensure that your Aerus Pure & Clean operates properly. The unit will display a PERFORM CLEANING reminder when it's time to perform regular maintenance. If you are operating your unit in a severely polluted environment, cleaning of the unit, ActivePure® Cell, and Filter Assembly should be done more frequently. Shown here are basic procedures that should be carried out to keep your unit running at top performance.

For optimal performance, and to prevent damage not covered by your warranty, install the Optional HEPA Filter. Failure to perform routine maintenance could adversely affect the proper function of the unit or cause it to fail prematurely.

NOTE: If a unit is returned for repair, and it is determined that neglect of the unit or unauthorized tampering with any mechanical or electronic component of the unit caused the failure, Aerus reserves the right to void the product warranty. This will require the owner to pay for any required repairs.

CLEANING THE CASE

Wipe the unit with a soft cloth dampened (not wet) with water. Do not use chemicals or solvents. Vacuum the Top and Rear Grills periodically to remove any lint buildup.

GENERAL MAINTENANCE (CONTINUED)



WARNING: Unplug the unit before performing any maintenance procedures.

CLEANING THE ACTIVEPURE® CELLS

Remove the ActivePure® Cells and carefully vacuum accumulated lint. Do not wash the ActivePure® Cells. Damage from water may result.

FILTER ASSEMBLY CLEANING

1. When visibly dirty, simply remove the rear Filter Assembly from the unit (see pages 7 - 8), and with a hand-held vacuum, remove the heavy particulate. This method will extend the life of the Filter Assembly.
2. If the Filter Assembly can't be cleaned by vacuuming, replace the Filter Assembly.

FILTER ASSEMBLY REPLACEMENT

Contact your Aerus Distributor for replacement filters. See pages 8 - 9 for removal and installation instructions.

CHANGING THE ACTIVEPURE® CELL

The ActivePure® Cell (RCI) should be replaced when REPLACE RCI CELL appears on the display, or twelve (12) months when used continuously or two (2) years if used less than 12 hours a day, whichever comes first. To change the ActivePure® Cell, follow the instructions on page 10.

UNINSTALLING THE OPTIONAL HEPA FILTER SHEET



WARNING: Unplug the unit before performing any maintenance procedures.

The Optional HEPA Filter Sheet is designed specifically for areas with tobacco smoke, multiple pets, or anywhere excessive levels of contamination are in the air.

- Protects your air purifier from indoor contaminants, which may shorten the life of your product
- Reduces monthly maintenance and cleaning time up to 90%
- Helps reduce odors
- Great in kitchen environments
- Helps reduce VOC's and other contaminants

NOTE: Removing the optional HEPA filter sheet will increase the airflow of the unit.

UNINSTALLING THE OPTIONAL HEPA FILTER SHEET (CONTINUED)

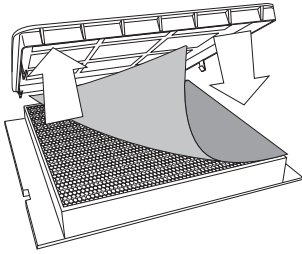

- 1a. Remove the Filter Assembly (see below).
- 1b. Remove the HEPA Filter Sheet on top of the Prefilter.

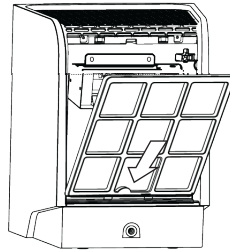

2. Replace the Filter Assembly, inserting the bottom of the Filter Assembly first.

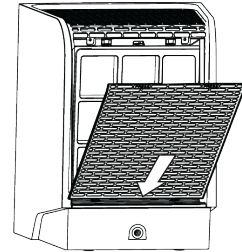

3. Replace the Back Cover by inserting the bottom in first and snapping into place.

REMOVING THE FILTER ASSEMBLY



WARNING: Unplug the unit before performing any maintenance procedures.



WARNING: Do not operate the Aerus Pure & Clean without the Filter Assembly and Back Cover properly installed.

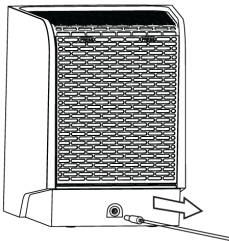

1. Unplug unit.

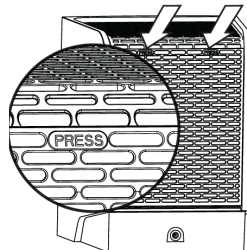

2. Press the top of the Back Cover to release the back panel.

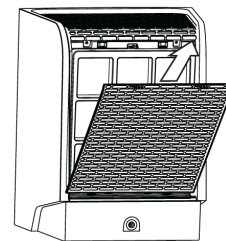

3. Lift up to remove the back panel.

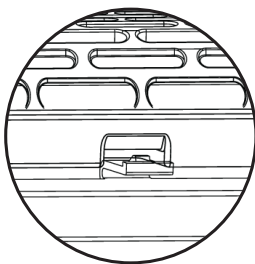

4. Press the tab down release the Filter Assembly.

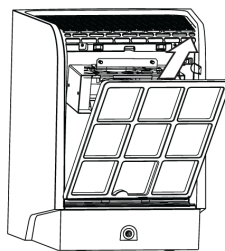

5. Lift the Filter Assembly up and out to remove.

REMOVING THE ACTIVEPURE® CELLS

WARNING: • Unplug the unit before performing any maintenance procedures
• Do not operate the Aerus Pure & Clean without the Filter Assembly and Back Cover properly installed

CAUTION: Do not look directly at the glowing lamp. Prolonged exposure, even to reflected UV light, can cause eye damage according to the American Conference of Governmental Industrial Hygienists (ACGIH) Standards.

NOTE: Use genuine Aerus replacement parts only. Parts from anyone other than Aerus may damage your unit and void your warranty.

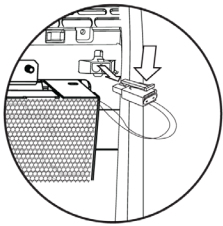

1. Unlock the ActivePure® Cell connector by pressing on the connector's locking tabs.

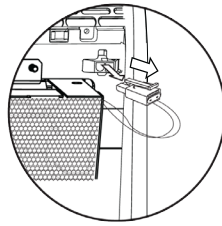

2. Pull the connector straight out to unplug.

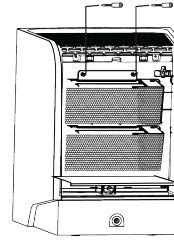

3. Remove two (2) thumbscrews.

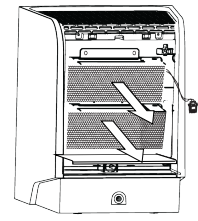

4. Slide the ActivePure® Cell down and out of unit.

INSTALLING THE ACTIVEPURE® CELLS

WARNING: • Unplug the unit before performing any maintenance procedures
• Do not operate the Aerus Pure & Clean without the Filter Assembly and Back Cover properly installed

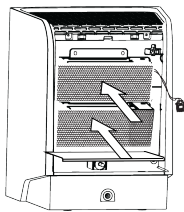

1. Slide the ActivePure® Cell up and into the unit. Be sure the back lip of the ActivePure® Cell engages the two slotted protrusions at the rear of the unit, and that the angle brackets and studs are correctly aligned.

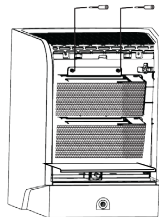

2. Insert the two thumbscrews and tighten. Insert the ActivePure® Cell connector into the plug at the rear of the unit.

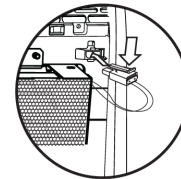

3. Press the connector firmly until the two tabs lock into place.

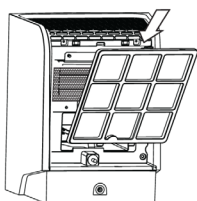

4. Replace the Filter Assembly, inserting the bottom of the Filter Assembly first.

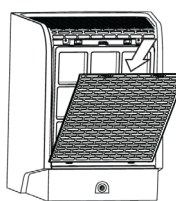

5. Replace the Back Cover by inserting the bottom in and snapping into place.

TROUBLESHOOTING

INDICATORS OF OPERATION

When the unit is on, the LCD display will show either the fan setting and A·PURE, A·PURE x2, or Ion.

TROUBLESHOOTING - WHAT TO LOOK FOR FIRST.

1. I have plugged in the unit, pressed the ON button on the Aerus Pure & Clean, and nothing happens. What's wrong?

- Make sure the power cord is inserted completely into the receptacle on the back of the unit
- Make sure the electrical outlet is capable of providing power to the unit

If you are operating your central heating and air conditioning fan, or other ventilation system continuously, set the coverage up to the total ventilated indoor area. Otherwise, set the coverage up to the size of the room.

2. The UV Lamp is not functioning/I'm getting a "Replace RCI Cell" Message.

- Check ActivePure® Cell for proper installation
- Replace the ActivePure® Cell

3. What are the most typical application problems?

- **Symptom:** A belief that the proper equipment is placed in the environment and the equipment appears unsuccessful
Problem: Lack of air movement, improper placement of the unit
- **Symptom:** Visual haze of smoke and/or particulate remain within the environment
Problem: Lack of ionization and/or air movement

4. Air flow is restricted or reduced.

- Is the unit properly placed away from objects that may obstruct air flow?
- Are the Filter Assembly, Back Cover, and Top and Rear Grill clean?
- Is the ActivePure® Cell clean?

5. How can I tell if the ActivePure® Cell is functioning?

- The ActivePure® Cell will produce a glow that is visible through the Top and Rear Grill under low light conditions

6. Unit does not operate.

- Is the unit plugged in?
- Are you sure the outlet is active?
- Are the Filter Assembly and Back Cover installed properly?

If your unit fails to operate properly after performing troubleshooting contact your Aerus Distributor or Aerus Customer Service for further assistance at 800.243.9078 (U.S.) or 800.668.0763 (CANADA) or email customerservice@aerusonline.com.

REPLACEMENT PARTS LIST

Item # 50106: ActivePure® Cell

Item # 50107: Filter Assembly

Item # 50108: Power Supply with U.S. / Euro Plug

To order replacement parts, contact your Aerus Distributor or Aerus Customer Service for further assistance at 800.243.9078 (U.S.) or 800.668.0763 (CANADA) or email customerservice@aerusonline.com.

LIMITED THREE (3) YEAR WARRANTY

WHAT IS COVERED BY THIS WARRANTY

We warrant the Aerus Pure & Clean (excluding filters and purification plates) to the consumer, subject to the conditions below, against defects in workmanship or material, provided that the products are returned to a service location within the following time periods:

- Aerus Pure & Clean within three (3) years of date of purchase
- ActivePure® Cell within ninety (90) days of date of purchase

INSTALLATION AND MAINTENANCE REQUIREMENTS

This warranty is expressly conditioned upon proper installation, operation, cleaning and maintenance, all in accordance with the Owner's Manual. Failure to meet any of these requirements will void this warranty. Servicing of your Aerus Pure & Clean by parties other than our authorized representative and/or using parts other than genuine parts will also void this warranty.

HOW TO OBTAIN WARRANTY SERVICE

Customer must contact Aerus Customer Service or their Aerus Distributor and provide proof of purchase within the above time period. We will repair or replace and return the product, without charge and within a reasonable period of time, subject to the conditions in the above paragraphs, if its examination shall disclose any part to be defective in workmanship or material. If we, in our discretion, are unable to repair the product after a reasonable number of attempts, we will provide either a refund of the purchase price or a replacement unit, at the company's option.

WHAT IS NOT COVERED BY THIS WARRANTY

This product is intended for household use only. Ordinary wear and tear shall not be considered a defect in workmanship or material. These warranties do not apply to filters nor for loss or damage caused by accident, fire, abuse, misuse, improper installation, modification, misapplication, commercial use, or by any repairs other than those provided by our authorized Service Center.

MISSING SERIAL NUMBERS AND UNAUTHORIZED CHANNELS

If a valid serial number is missing from the product, the warranty will be voided. Aerus products are authorized for sale through Aerus Distributors only. Warranties are voided if a product is purchased through unauthorized channels, this includes websites that are not authorized to sell our products OR to use Aerus trademarked names, images and logos as well as Internet auction sites (e.g. ebay and Craigslist). The only approved Internet presence for Aerus products is www.aerushome.com. To confirm warranty coverage prior to purchasing a product, contact Aerus at 800.243.9078 (U.S.) or 800.668.0763 (CANADA) with the serial number located on the back of the unit.

EXCLUSION OF OTHER WARRANTIES AND CONDITIONS

EXCEPT AS PROVIDED HEREIN, WE MAKE NO REPRESENTATION OR WARRANTY OF ANY KIND. ALL OTHER WARRANTIES OF ANY KIND, EXPRESS OR IMPLIED, ARE HEREBY EXPRESSLY DISCLAIMED, INCLUDING ANY IMPLIED WARRANTY OF MERCHANTABILITY OR FITNESS FOR A PARTICULAR PURPOSE.

LIMITATION OF LIABILITY FOR SPECIAL, INCIDENTAL, OR CONSEQUENTIAL DAMAGES

WE SHALL NOT IN ANY CASE BE LIABLE FOR SPECIAL, INCIDENTAL OR CONSEQUENTIAL DAMAGES ARISING FROM BREACH OF EXPRESSED OR IMPLIED WARRANTIES, CONDITIONS, GUARANTEES OR REPRESENTATIONS, BREACH OF CONTRACT, NEGLIGENCE OR ANY OTHER LEGAL THEORY. Such excluded damages include, but are not limited to, loss of profits or revenue, and loss of the use of the products.

FOR U.S. APPLICATION ONLY

This warranty gives you specific legal rights, and you may also have other rights which vary from state to state. Some states do not allow limitations on warranties, or on remedies for breach. In such states, the above limitations may not apply to you.

FOR CANADIAN APPLICATION ONLY

Exclusion of Subsequent Owners: Except as otherwise required by applicable legislation, this warranty is not transferable. This warranty gives you specific legal rights and you may also have other rights which vary from province to province. Some provinces and territories do not allow limitations on warranties, or on remedies for breach. In such provinces or territories, the above limitations may not apply to you. If any provision of this warranty or part thereof is held by a court of competent jurisdiction to be invalid, illegal, or unenforceable, the validity, legality and enforceability of the remaining provisions or parts thereof will not in any way be affected or impaired within the jurisdiction of that court. This entire warranty shall continue to be valid, legal and enforceable in any jurisdiction where a similar determination has not been made.

This warranty is provided by:

Aerus, LLC
300 East Valley Drive
Bristol, VA 24201

SERVICE

Every effort is made to ensure customers receive an up-to-date instructions manual on the use of our products; however, from time to time, modifications to our products may without notice make the information contained herein subject to alteration. For the latest information, please visit our website at www.aerushome.com.

This equipment has been tested and found to comply with the limits for a Class B digital device, pursuant of part 15 of the FCC Rules. These limits are designed to provide reasonable protection against harmful interference in a residential installation. This equipment generates, uses, and can radiate radio frequency energy, and if not installed and used in accordance with the instructions, may cause harmful interference to radio communications. However, there is no guarantee that interference will not occur in a particular installation. If this equipment does cause harmful interference to radio or television, which can be determined by turning the equipment off and on, the user is encouraged to try to correct the interference by one or more of the following measures:

Reorient or relocate the receiving antenna.

Increase the separation between the equipment and receiver.

Connect the equipment into an outlet on a circuit different from that to which the receiver is connected.

Consult the Independent Business Owner for help.

FCC Declaration of Conformity

Name: Aerus Pure & Clean

Model: A1040A

Manufacturer: Aerus, LLC

This device complies with Part 15 of the FCC Rules.

RESPONSIBLE PARTY

Aerus, LLC
300 East Valley Drive
Bristol, VA 24201
Ph: 800.243.9078 (U.S.)

Signature: _____



Printed Name: Andrew Eide

Title: Vice President of Product Development
and Manufacturing

Date: 03/23/2020

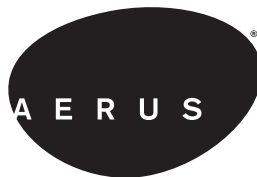

For information regarding the use of this product please call Customer Service.

800.243.9078 (U.S.)

800.668.0768 (CANADA)

www.aerushome.com

Aerus, LLC | 300 East Valley Drive | Bristol, VA 24201 | 800.243.9078

© 2020 Aerus LLC. All Rights Reserved